

Parachèvement de l'autoroute 19 à Laval et à Bois-des-Filion

Étude d'intersection

Comptages 2012

Intersection de la route 335 et de l'avenue des Perron / rue Saint-Saëns Est

Numéro du relevé: 0081357 Type d'étude: Passagers Étude piétons: Piétons
 Identifiant du carrefour: 31240 Camions (#081358) Vélos
 Municipalité: Laval Autobus
 Direction Territoriale: Laval--Mille-Îles Centre de service: 8406
 Projet: Manuel 2012

Relevé de 7:00 à 19:00
 Date du relevé (avant-midi): 12-11-15 Jeudi Ensoleillé
 Date du relevé (après-midi): 12-11-15 Jeudi Ensoleillé

	route	section de trafic djma officiel	profil	% commercial	djma	djme	djmh	fpi
Nord	00335-01-140 (00+436) avenue Papineau	0033524000 23500 (2011)	1	5.6	22100	23800	19800	0.90
Sud	00335-01-140 (00+000) avenue Papineau	0033523000 29000 (2011)	1	5.2	25000	27000	22000	0.94
Est	avenue des Perron		1	3.9	2310	2490	2070	0.87
Ouest	avenue des Perron		1	3.3	7800	8400	7000	0.91

Heure de pointe: 15:00 à 16:00
 Facteur de pointe instantanée: 0.96

Djma entrant: 29000
 % commercial: 5.0

Numéro du relevé: 0081357 Municipalité: Laval
Direction Territoriale: Laval--Mille-Îles

Avant-midi: 12-11-15 Jeudi
Après-midi: 12-11-15 Jeudi
Relevé de 7:00 à 19:00

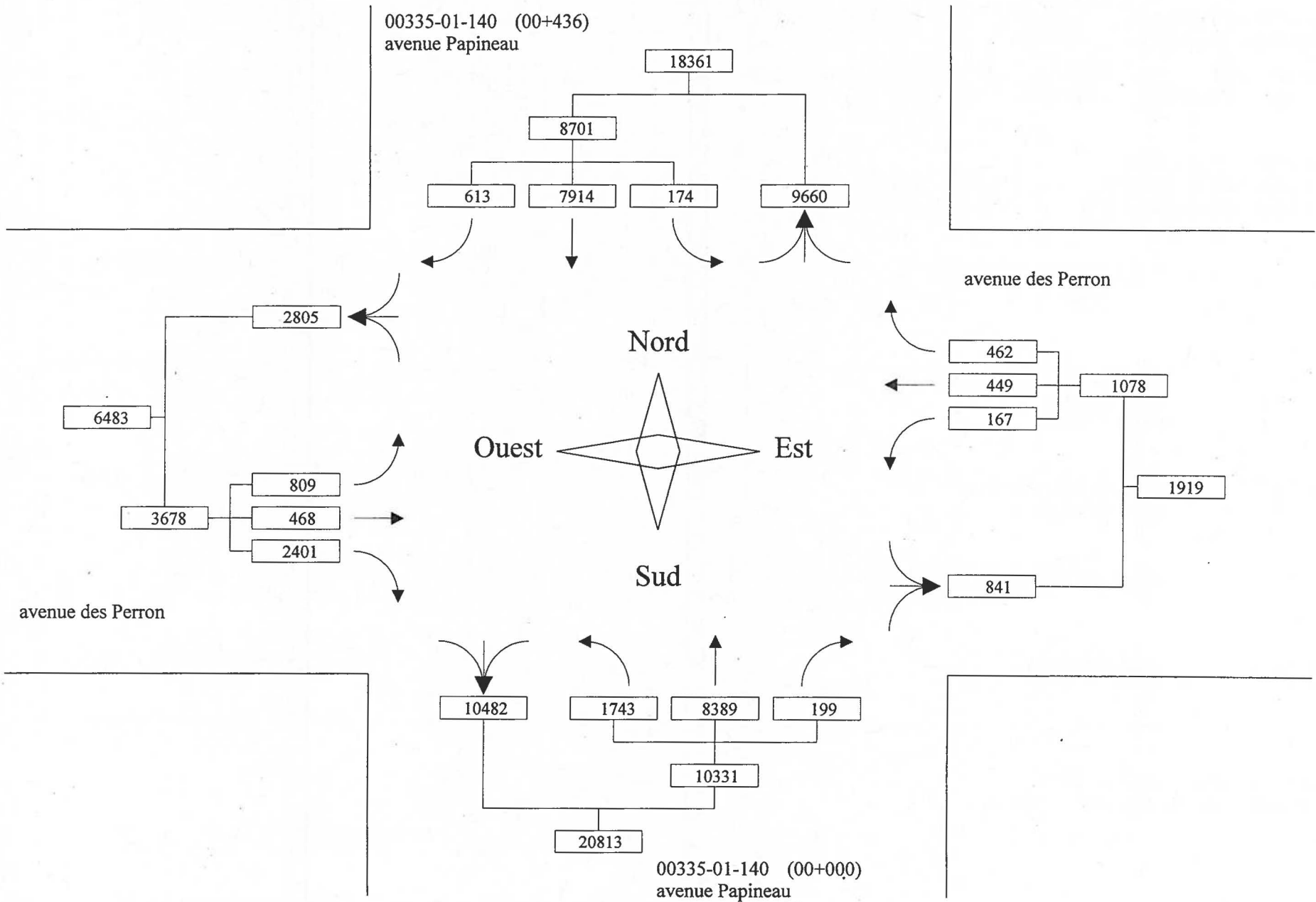

Numéro du relevé: 0081357 Municipalité: Laval
 Direction Territoriale: Laval--Mille-Îles

Avant-midi: 12-11-15 Jeudi
 Après-midi: 12-11-15 Jeudi
 Relevé de 7:00 à 19:00

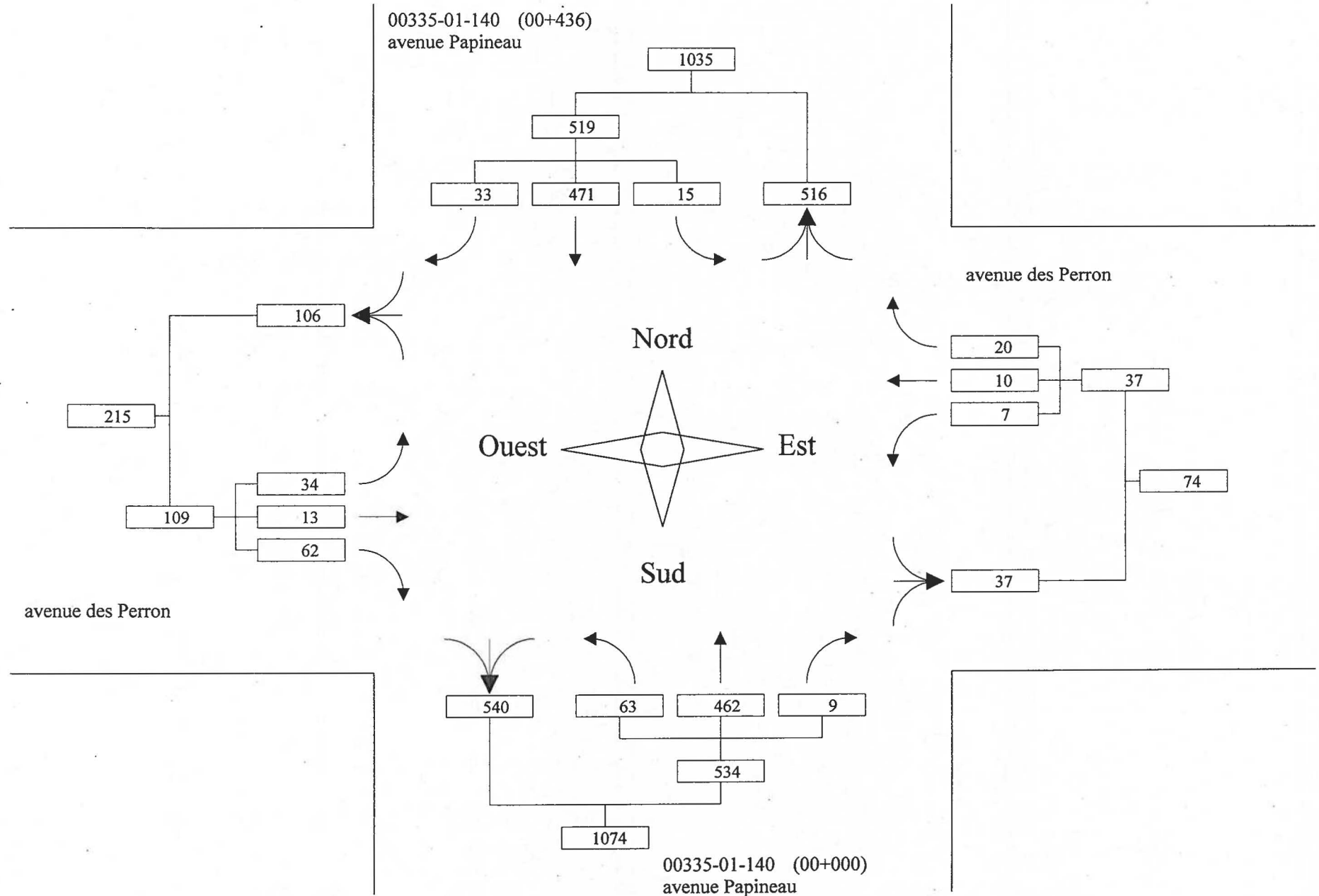

Numéro du relevé: 0081357 Municipalité: Laval
Direction Territoriale: Laval--Mille-Îles

Avant-midi: 12-11-15 Jeudi
Après-midi: 12-11-15 Jeudi
Relevé de 7:00 à 19:00

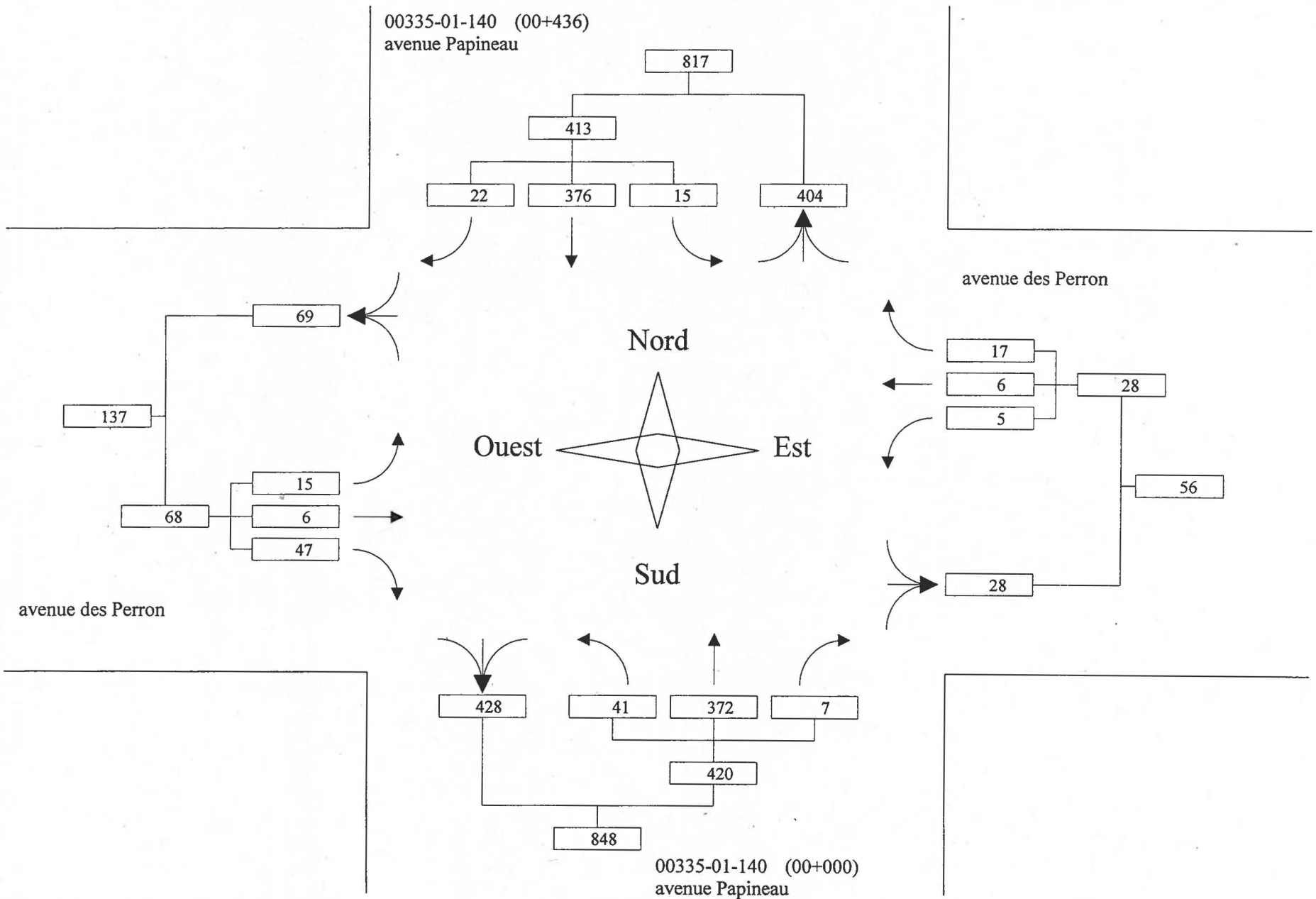

Numéro du relevé: 0081357 Municipalité: Laval
Direction Territoriale: Laval--Mille-Îles

Avant-midi: 12-11-15 Jeudi
Après-midi: 12-11-15 Jeudi
Relevé de 7:00 à 19:00

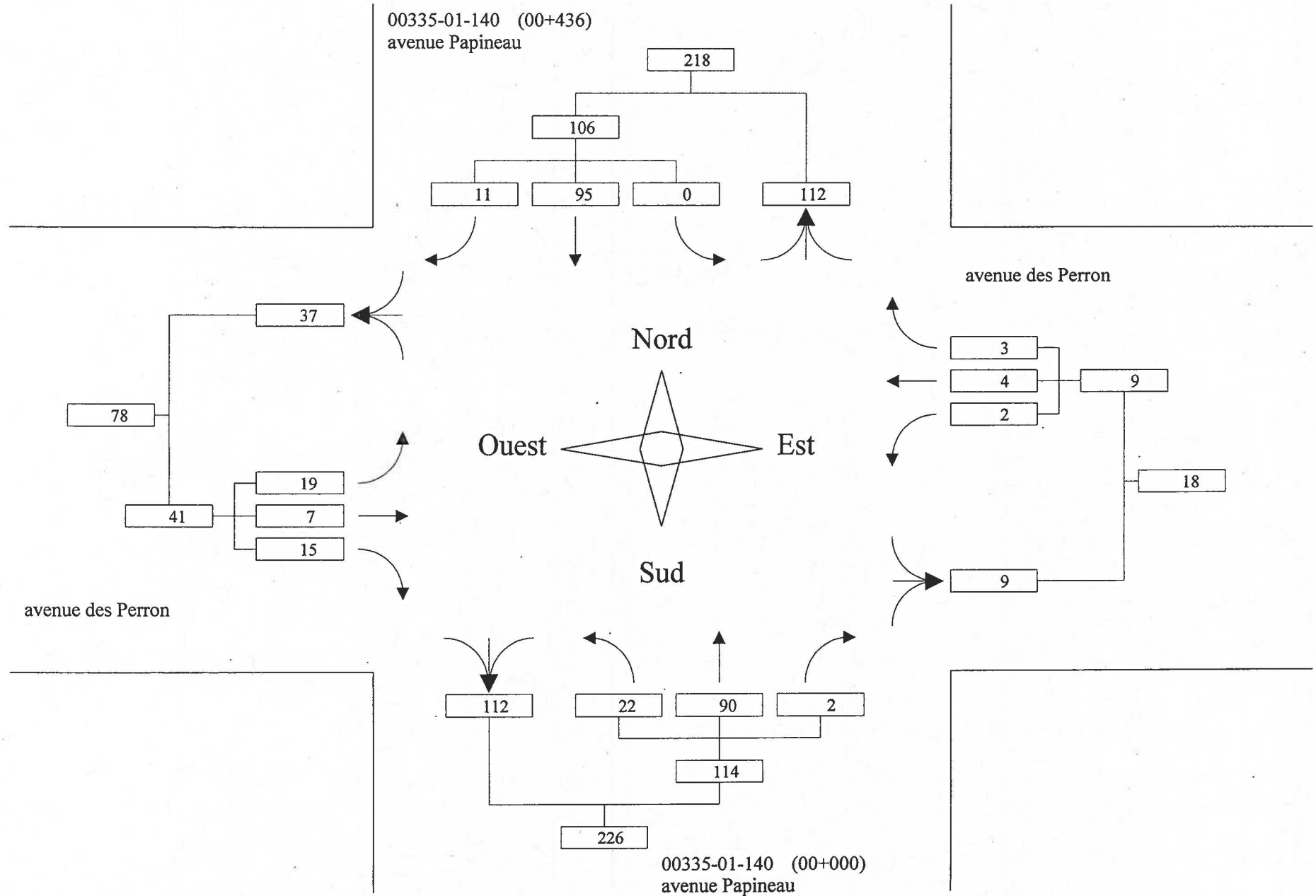

Numéro du relevé: 0081357 Municipalité: Laval
Direction Territoriale: Laval--Mille-Îles

Avant-midi: 12-11-15 Jeudi
Après-midi: 12-11-15 Jeudi
Relevé de 7:00 à 19:00

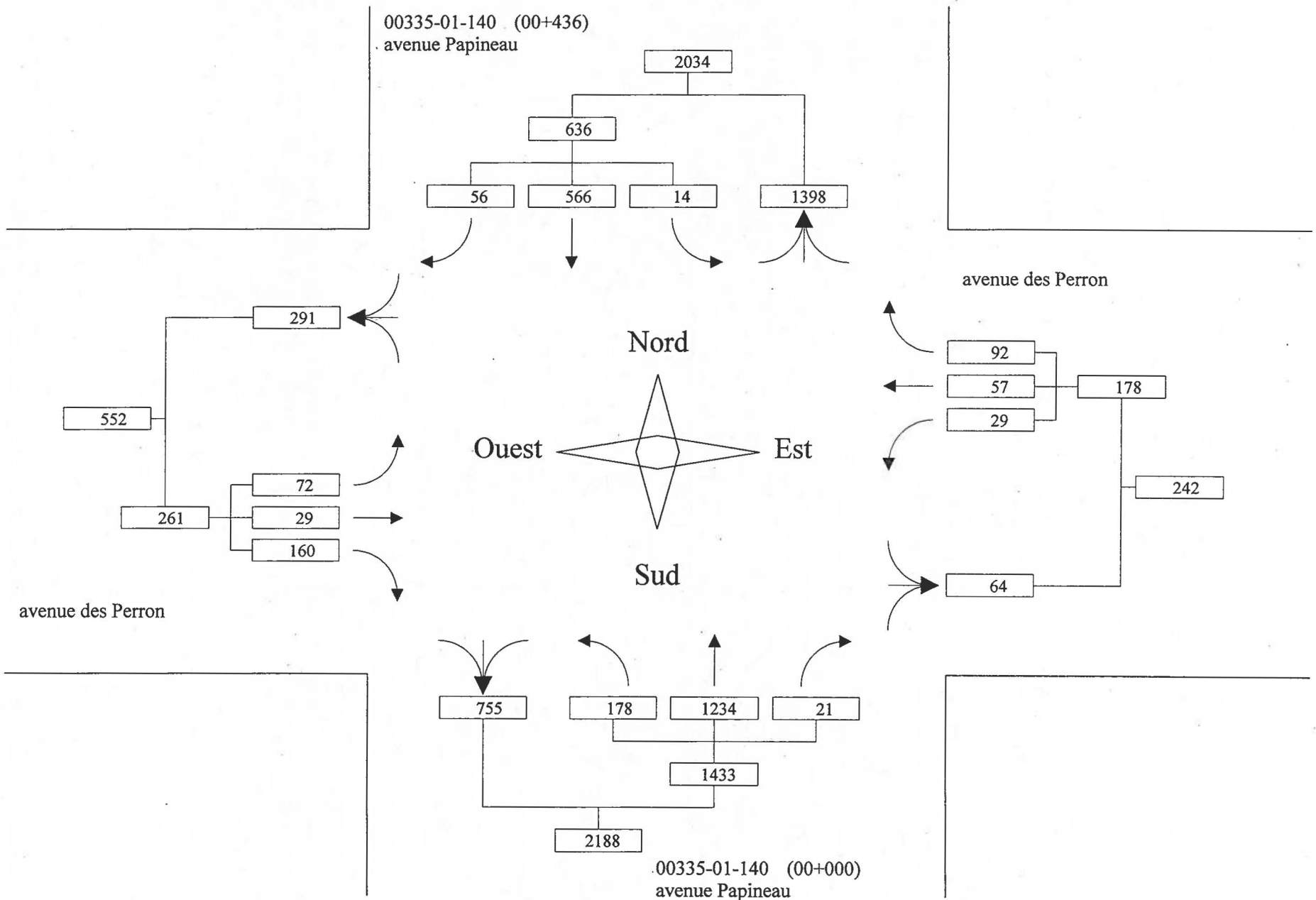

Numéro du relevé: 0081357 Municipalité: Laval
Direction Territoriale: Laval--Mille-Îles

Avant-midi: 12-11-15 Jeudi
Après-midi: 12-11-15 Jeudi
Relevé de 7:00 à 19:00

Nord: 00335-01-140 (00+436) avenue Papineau
Sud: 00335-01-140 (00+000) avenue Papineau

Est: avenue des Perron
Ouest: avenue des Perron

	Nord avenue Papineau				Sud avenue Papineau				Est avenue des Perron				Ouest avenue des Perron				Grand Total	% Horaire
	←	↑	→	Total	←	↑	→	Total	←	↑	→	Total	←	↑	→	Total		
7:00- 8:00	25	934	20	979	79	454	14	547	7	36	5	48	74	116	325	515	2089	8.8
8:00- 9:00	29	1009	21	1059	129	522	14	665	7	35	5	47	58	65	231	354	2125	8.9
9:00-10:00	15	896	53	964	121	307	13	441	10	20	5	35	37	23	222	282	1722	7.2
10:00-11:00	12	683	54	749	113	423	11	547	13	13	7	33	40	14	235	289	1618	6.8
11:00-12:00	9	601	48	658	143	473	18	634	16	17	7	40	45	13	146	204	1536	6.5
12:00-13:00	11	580	42	633	164	531	15	710	19	14	13	46	46	13	200	259	1648	6.9
13:00-14:00	9	549	50	608	159	668	22	849	15	24	15	54	49	20	186	255	1766	7.4
14:00-15:00	13	642	63	718	221	925	36	1182	15	26	33	74	59	22	200	281	2255	9.5
15:00-16:00	14	566	56	636	178	1234	21	1433	29	57	92	178	72	29	160	261	2508	10.5
16:00-17:00	15	573	79	667	87	910	6	1003	16	82	140	238	140	71	149	360	2268	9.5
17:00-18:00	13	467	77	557	91	877	8	976	14	81	103	198	125	50	149	324	2055	8.6
18:00-19:00	9	414	50	473	258	1065	21	1344	6	44	37	87	64	32	198	294	2198	9.2
Total	174	7914	613	8701	1743	8389	199	10331	167	449	462	1078	809	468	2401	3678	23788	100
% de approche	2.0	91.0	7.0		16.9	81.2	1.9		15.5	41.7	42.9		22.0	12.7	65.3			

Numéro du relevé: 0081357 Municipalité: Laval
Direction Territoriale: Laval--Mille-Îles

Avant-midi: 12-11-15 Jeudi
Après-midi: 12-11-15 Jeudi
Relevé de 7:00 à 19:00

Nord: 00335-01-140 (00+436) avenue Papineau
Sud: 00335-01-140 (00+000) avenue Papineau

Est: avenue des Perron
Ouest: avenue des Perron

	Nord avenue Papineau				Sud avenue Papineau				Est avenue des Perron				Ouest avenue des Perron				Grand Total	% Horaire
	←	↑	→	Total	←	↑	→	Total	←	↑	→	Total	←	↑	→	Total		
7:00- 8:00	0	29	0	29	3	35	0	38	0	3	2	5	3	3	2	8	80	6.7
8:00- 9:00	1	36	2	39	6	58	0	64	0	1	1	2	5	0	4	9	114	9.5
9:00-10:00	2	55	6	63	11	40	0	51	0	1	1	2	1	1	7	9	125	10.4
10:00-11:00	0	53	3	56	11	40	2	53	1	1	1	3	1	2	7	10	122	10.2
11:00-12:00	0	42	1	43	5	36	2	43	3	1	0	4	0	0	5	5	95	7.9
12:00-13:00	1	42	3	46	6	36	0	42	0	0	0	0	2	0	7	9	97	8.1
13:00-14:00	2	42	3	47	6	69	2	77	0	2	0	2	1	1	9	11	137	11.4
14:00-15:00	2	70	3	75	6	47	1	54	1	0	2	3	5	1	6	12	144	12.0
15:00-16:00	2	46	3	51	4	42	1	47	2	0	6	8	3	1	3	7	113	9.4
16:00-17:00	2	21	5	28	1	22	0	23	0	1	2	3	8	3	10	21	75	6.3
17:00-18:00	1	24	3	28	0	22	0	22	0	0	4	4	5	0	1	6	60	5.0
18:00-19:00	2	11	1	14	4	15	1	20	0	0	1	1	0	1	1	2	37	3.1
Total	15	471	33	519	63	462	9	534	7	10	20	37	34	13	62	109	1199	100
% de approche	2.9	90.8	6.4		11.8	86.5	1.7		18.9	27.0	54.1		31.2	11.9	56.9			

Numéro du relevé: 0081357 Municipalité: Laval
Direction Territoriale: Laval--Mille-Îles

Avant-midi: 12-11-15 Jeudi
Après-midi: 12-11-15 Jeudi
Relevé de 7:00 à 19:00

Nord: 00335-01-140 (00+436) avenue Papineau
Sud: 00335-01-140 (00+000) avenue Papineau

Est: avenue des Perron
Ouest: avenue des Perron

	Nord avenue Papineau			Total	Sud avenue Papineau			Total	Est avenue des Perron			Total	Ouest avenue des Perron			Total	Grand Total	% Horaire
	←	↑	→		←	↑	→		←	↑	→		←	↑	→			
7:00- 8:00	0	22	0	22	2	22	0	24	0	1	2	3	2	1	1	4	53	5.7
8:00- 9:00	1	35	1	37	4	36	0	40	0	0	1	1	2	0	3	5	83	8.9
9:00-10:00	2	50	2	54	0	33	0	33	0	1	1	2	1	0	5	6	95	10.2
10:00-11:00	0	48	3	51	9	37	2	48	1	1	1	3	1	2	6	9	111	11.9
11:00-12:00	0	37	0	37	5	33	1	39	2	1	0	3	0	0	4	4	83	8.9
12:00-13:00	1	40	3	44	5	35	0	40	0	0	0	0	2	0	5	7	91	9.8
13:00-14:00	2	36	3	41	4	49	2	55	0	2	0	2	0	1	5	6	104	11.2
14:00-15:00	2	40	3	45	4	43	1	48	1	0	2	3	0	0	4	4	100	10.8
15:00-16:00	2	32	3	37	3	34	0	37	1	0	5	6	2	1	3	6	86	9.3
16:00-17:00	2	16	3	21	1	20	0	21	0	0	1	1	3	0	9	12	55	5.9
17:00-18:00	1	15	0	16	0	20	0	20	0	0	3	3	2	0	1	3	42	4.5
18:00-19:00	2	5	1	8	4	10	1	15	0	0	1	1	0	1	1	2	26	2.8
Total	15	376	22	413	41	372	7	420	5	6	17	28	15	6	47	68	929	100
% de approche	3.6	91.0	5.3		9.8	88.6	1.7		17.9	21.4	60.7		22.1	8.8	69.1			

Numéro du relevé: 0081357 Municipalité: Laval
Direction Territoriale: Laval--Mille-Îles

Avant-midi: 12-11-15 Jeudi
Après-midi: 12-11-15 Jeudi
Relevé de 7:00 à 19:00

Nord: 00335-01-140 (00+436) avenue Papineau
Sud: 00335-01-140 (00+000) avenue Papineau

Est: avenue des Perron
Ouest: avenue des Perron

	Nord avenue Papineau			Total	Sud avenue Papineau			Total	Est avenue des Perron			Total	Ouest avenue des Perron			Total	Grand Total	% Horaire
	←	↑	→		←	↑	→		←	↑	→		←	↑	→			
7:00- 8:00	0	7	0	7	1	13	0	14	0	2	0	2	1	2	1	4	27	10.0
8:00- 9:00	0	1	1	2	2	22	0	24	0	1	0	1	3	0	1	4	31	11.5
9:00-10:00	0	5	4	9	11	7	0	18	0	0	0	0	0	1	2	3	30	11.1
10:00-11:00	0	5	0	5	2	3	0	5	0	0	0	0	0	0	1	1	11	4.1
11:00-12:00	0	5	1	6	0	3	1	4	1	0	0	1	0	0	1	1	12	4.4
12:00-13:00	0	2	0	2	1	1	0	2	0	0	0	0	0	0	2	2	6	2.2
13:00-14:00	0	6	0	6	2	20	0	22	0	0	0	0	1	0	4	5	33	12.2
14:00-15:00	0	30	0	30	2	4	0	6	0	0	0	0	5	1	2	8	44	16.3
15:00-16:00	0	14	0	14	1	8	1	10	1	0	1	2	1	0	0	1	27	10.0
16:00-17:00	0	5	2	7	0	2	0	2	0	1	1	2	5	3	1	9	20	7.4
17:00-18:00	0	9	3	12	0	2	0	2	0	0	1	1	3	0	0	3	18	6.7
18:00-19:00	0	6	0	6	0	5	0	5	0	0	0	0	0	0	0	0	11	4.1
Total	0	95	11	106	22	90	2	114	2	4	3	9	19	7	15	41	270	100
% de approche	0.0	89.6	10.4		19.3	78.9	1.8		22.2	44.4	33.3		46.3	17.1	36.6			

Numéro du relevé: 0081357 Municipalité: Laval
Direction Territoriale: Laval--Mille-Îles

Avant-midi: 12-11-15 Jeudi
Après-midi: 12-11-15 Jeudi
Relevé de 7:00 à 19:00

Nord: 00335-01-140 (00+436) avenue Papineau
Sud: 00335-01-140 (00+000) avenue Papineau

Est: avenue des Perron
Ouest: avenue des Perron

	Nord avenue Papineau				Sud avenue Papineau				Est avenue des Perron				Ouest avenue des Perron				Grand Total
	←	↑	→	Total	←	↑	→	Total	←	↑	→	Total	←	↑	→	Total	
7:30- 7:45	9	234	3	246	19	113	4	136	2	10	3	15	25	28	71	124	521
7:45- 8:00	7	265	9	281	23	134	2	159	0	11	1	12	16	21	58	95	547
8:00- 8:15	15	252	2	269	29	133	0	162	2	8	0	10	12	27	69	108	549
8:15- 8:30	7	254	6	267	45	144	6	195	0	9	0	9	12	14	50	76	547
Total pointe	38	1005	20	1063	116	524	12	652	4	38	4	46	65	90	248	403	2164
fpi	0.63	0.95	0.56	0.95	0.64	0.91	0.50	0.84	0.50	0.86	0.33	0.77	0.65	0.80	0.87	0.81	0.99
% commercial	0.0	3.5	5.0	3.4	3.4	9.5	0.0	8.3	0.0	5.3	25.0	6.5	3.1	3.3	0.8	1.7	4.6
13:00-13:15	4	140	12	156	52	174	7	233	4	4	1	9	9	5	51	65	463
13:15-13:30	0	129	19	148	25	138	5	168	1	5	7	13	10	2	48	60	389
13:30-13:45	2	157	12	171	40	162	8	210	5	8	3	16	17	6	39	62	459
13:45-14:00	3	123	7	133	42	194	2	238	5	7	4	16	13	7	48	68	455
Total pointe	9	549	50	608	159	668	22	849	15	24	15	54	49	20	186	255	1766
fpi	0.56	0.87	0.66	0.89	0.76	0.86	0.69	0.89	0.75	0.75	0.54	0.84	0.72	0.71	0.91	0.94	0.95
% commercial	22.2	7.7	6.0	7.7	3.8	10.3	9.1	9.1	0.0	8.3	0.0	3.7	2.0	5.0	4.8	4.3	7.8
15:00-15:15	6	135	17	158	56	316	9	381	8	10	22	40	17	3	52	72	651
15:15-15:30	3	142	10	155	50	294	6	350	8	14	17	39	22	6	38	66	610
15:30-15:45	3	156	17	176	32	320	2	354	7	17	24	48	16	5	36	57	635
15:45-16:00	2	133	12	147	40	304	4	348	6	16	29	51	17	15	34	66	612
Total pointe	14	566	56	636	178	1234	21	1433	29	57	92	178	72	29	160	261	2508
fpi	0.58	0.91	0.82	0.90	0.79	0.96	0.58	0.94	0.91	0.84	0.79	0.87	0.82	0.48	0.77	0.91	0.96
% commercial	14.3	8.1	5.4	8.0	2.2	3.4	4.8	3.3	6.9	0.0	6.5	4.5	4.2	3.4	1.9	2.7	4.5

Numéro du relevé: 0081357 Municipalité: Laval
Direction Territoriale: Laval--Mille-Îles

Avant-midi: 12-11-15 Jeudi
Après-midi: 12-11-15 Jeudi
Relevé de 7:00 à 19:00

Nord: 00335-01-140 (00+436) avenue Papineau
Sud: 00335-01-140 (00+000) avenue Papineau

Est: avenue des Perron
Ouest: avenue des Perron

Type1: Piétons

Type2: Vélos

Type3: --nil--

	Nord				Sud				Est				Ouest				Grand Total
	avenue Papineau				avenue Papineau				avenue des Perron				avenue des Perron				
	Type1	Type2	Type3	Total	Type1	Type2	Type3	Total	Type1	Type2	Type3	Total	Type1	Type2	Type3	Total	
7:00- 7:15	0	0	0	0	0	0	0	0	0	0	0	0	0	0	0	0	0
7:15- 7:30	0	0	0	0	0	0	0	0	0	0	0	0	0	0	0	0	0
7:30- 7:45	0	0	0	0	0	0	0	0	0	0	0	0	0	0	0	0	0
7:45- 8:00	0	0	0	0	0	0	0	0	0	0	0	0	0	0	0	0	0
8:00- 8:15	0	0	0	0	0	0	0	0	0	0	0	0	0	0	0	0	0
8:15- 8:30	0	0	0	0	0	0	0	0	0	0	0	0	0	0	0	0	0
8:30- 8:45	0	0	0	0	0	0	0	0	0	0	0	0	0	0	0	0	0
8:45- 9:00	0	0	0	0	0	1	0	1	0	0	0	0	0	0	0	0	1
9:00- 9:15	0	0	0	0	0	0	0	0	0	0	0	0	0	0	0	0	0
9:15- 9:30	0	0	0	0	0	0	0	0	0	0	0	0	0	0	0	0	0
9:30- 9:45	0	0	0	0	0	0	0	0	0	0	0	0	0	0	0	0	0
9:45-10:00	0	0	0	0	0	0	0	0	0	0	0	0	0	0	0	0	0
10:00-10:15	0	0	0	0	0	0	0	0	0	0	0	0	0	0	0	0	0
10:15-10:30	0	0	0	0	0	0	0	0	0	0	0	0	0	0	0	0	0
10:30-10:45	0	0	0	0	0	0	0	0	0	0	0	0	0	0	0	0	0
10:45-11:00	0	0	0	0	0	0	0	0	0	0	0	0	0	0	0	0	0
11:00-11:15	0	0	0	0	0	0	0	0	0	0	0	0	0	0	0	0	0
11:15-11:30	0	0	0	0	0	0	0	0	0	0	0	0	0	0	0	0	0
11:30-11:45	0	0	0	0	0	0	0	0	0	0	0	0	0	0	0	0	0
11:45-12:00	0	0	0	0	0	0	0	0	0	0	0	0	0	0	0	0	0
12:00-12:15	0	0	0	0	0	0	0	0	0	0	0	0	0	0	0	0	0
12:15-12:30	0	0	0	0	0	0	0	0	0	0	0	0	0	0	0	0	0
12:30-12:45	0	0	0	0	0	0	0	0	0	0	0	0	0	0	0	0	0
12:45-13:00	0	0	0	0	0	0	0	0	0	0	0	0	0	1	0	1	1

Numéro du relevé: 0081357 Municipalité: Laval
Direction Territoriale: Laval--Mille-Îles

Avant-midi: 12-11-15 Jeudi
Après-midi: 12-11-15 Jeudi
Relevé de 7:00 à 19:00

Nord: 00335-01-140 (00+436) avenue Papineau
Sud: 00335-01-140 (00+000) avenue Papineau

Est: avenue des Perron
Ouest: avenue des Perron

Type1: Piétons

Type2: Vélos

Type3: --nil--

	Nord avenue Papineau				Sud avenue Papineau				Est avenue des Perron				Ouest avenue des Perron				Grand Total
	Type1	Type2	Type3	Total	Type1	Type2	Type3	Total	Type1	Type2	Type3	Total	Type1	Type2	Type3	Total	
13:00-13:15	0	0	0	0	0	0	0	0	0	0	0	0	0	0	0	0	0
13:15-13:30	0	0	0	0	0	0	0	0	0	0	0	0	0	0	0	0	0
13:30-13:45	0	0	0	0	0	0	0	0	0	0	0	0	0	0	0	0	0
13:45-14:00	0	0	0	0	0	0	0	0	0	0	0	0	0	0	0	0	0
14:00-14:15	0	0	0	0	0	0	0	0	0	0	0	0	0	0	0	0	0
14:15-14:30	0	0	0	0	0	0	0	0	0	0	0	0	0	0	0	0	0
14:30-14:45	0	1	0	1	0	0	0	0	0	0	0	0	0	0	0	0	1
14:45-15:00	0	0	0	0	0	0	0	0	0	0	0	0	0	0	0	0	0
15:00-15:15	0	0	0	0	0	0	0	0	0	0	0	0	0	1	0	1	1
15:15-15:30	0	0	0	0	0	0	0	0	0	0	0	0	0	0	0	0	0
15:30-15:45	0	0	0	0	0	0	0	0	0	0	0	0	0	0	0	0	0
15:45-16:00	0	0	0	0	0	0	0	0	0	0	0	0	0	0	0	0	0
16:00-16:15	0	0	0	0	0	0	0	0	0	0	0	0	0	0	0	0	0
16:15-16:30	0	0	0	0	0	0	0	0	0	0	0	0	0	0	0	0	0
16:30-16:45	0	0	0	0	0	0	0	0	0	0	0	0	0	0	0	0	0
16:45-17:00	0	0	0	0	0	0	0	0	0	0	0	0	0	0	0	0	0
17:00-17:15	0	0	0	0	0	0	0	0	0	0	0	0	0	0	0	0	0
17:15-17:30	0	0	0	0	0	0	0	0	0	0	0	0	0	0	0	0	0
17:30-17:45	0	0	0	0	0	0	0	0	0	0	0	0	0	0	0	0	0
17:45-18:00	0	0	0	0	0	0	0	0	0	0	0	0	0	0	0	0	0
18:00-18:15	0	0	0	0	0	0	0	0	0	0	0	0	0	0	0	0	0
18:15-18:30	0	0	0	0	0	0	0	0	0	0	0	0	0	0	0	0	0
18:30-18:45	0	0	0	0	0	0	0	0	0	0	0	0	0	0	0	0	0
18:45-19:00	0	0	0	0	0	0	0	0	0	0	0	0	0	0	0	0	0
Total	0	1	0	1	0	1	0	1	0	0	0	0	0	2	0	2	4

Numéro du relevé: 0081357 Municipalité: Laval
Direction Territoriale: Laval--Mille-Îles

Avant-midi: 12-11-15 Jeudi
Après-midi: 12-11-15 Jeudi
Relevé de 7:00 à 19:00

Nord: 00335-01-140 (00+436) avenue Papineau
Sud: 00335-01-140 (00+000) avenue Papineau

Est: avenue des Perron
Ouest: avenue des Perron

	Nord				Sud				Est				Ouest				Grand Total	%
	←	↑	→	Total	←	↑	→	Total	←	↑	→	Total	←	↑	→	Total		
7:00- 7:15	3	221	5	229	15	87	3	105	4	6	1	11	14	33	100	147	492	2.1
7:15- 7:30	6	214	3	223	22	120	5	147	1	9	0	10	19	34	96	149	529	2.2
7:30- 7:45	9	234	3	246	19	113	4	136	2	10	3	15	25	28	71	124	521	2.2
7:45- 8:00	7	265	9	281	23	134	2	159	0	11	1	12	16	21	58	95	547	2.3
8:00- 8:15	15	252	2	269	29	133	0	162	2	8	0	10	12	27	69	108	549	2.3
8:15- 8:30	7	254	6	267	45	144	6	195	0	9	0	9	12	14	50	76	547	2.3
8:30- 8:45	2	250	6	258	24	129	4	157	4	7	1	12	18	17	54	89	516	2.2
8:45- 9:00	5	253	7	265	31	116	4	151	1	11	4	16	16	7	58	81	513	2.2
9:00- 9:15	6	252	12	270	37	101	7	145	2	3	2	7	11	7	47	65	487	2.0
9:15- 9:30	4	225	16	245	34	25	3	62	3	7	2	12	12	8	60	80	399	1.7
9:30- 9:45	3	214	16	233	25	75	2	102	4	6	0	10	8	5	65	78	423	1.8
9:45-10:00	2	205	9	216	25	106	1	132	1	4	1	6	6	3	50	59	413	1.7
10:00-10:15	5	166	9	180	16	86	6	108	2	3	3	8	11	4	63	78	374	1.6
10:15-10:30	2	170	15	187	34	121	1	156	5	2	3	10	6	2	54	62	415	1.7
10:30-10:45	3	184	12	199	27	111	3	141	3	4	1	8	11	5	54	70	418	1.8
10:45-11:00	2	163	18	183	36	105	1	142	3	4	0	7	12	3	64	79	411	1.7
11:00-11:15	3	126	8	137	29	119	5	153	2	2	2	6	9	2	39	50	346	1.5
11:15-11:30	2	170	12	184	38	123	4	165	7	7	2	16	13	5	31	49	414	1.7
11:30-11:45	2	155	15	172	41	98	2	141	2	4	2	8	11	3	37	51	372	1.6
11:45-12:00	2	150	13	165	35	133	7	175	5	4	1	10	12	3	39	54	404	1.7
12:00-12:15	4	140	15	159	38	126	2	166	3	6	6	15	12	9	51	72	412	1.7
12:15-12:30	2	129	8	139	37	138	5	180	3	2	1	6	14	0	49	63	388	1.6
12:30-12:45	2	139	8	149	48	136	1	185	7	4	1	12	16	4	50	70	416	1.7
12:45-13:00	3	172	11	186	41	131	7	179	6	2	5	13	4	0	50	54	432	1.8

Numéro du relevé: 0081357 Municipalité: Laval
Direction Territoriale: Laval--Mille-Îles

Avant-midi: 12-11-15 Jeudi
Après-midi: 12-11-15 Jeudi
Relevé de 7:00 à 19:00

Nord: 00335-01-140 (00+436) avenue Papineau
Sud: 00335-01-140 (00+000) avenue Papineau

Est: avenue des Perron
Ouest: avenue des Perron

	Nord avenue Papineau				Sud avenue Papineau				Est avenue des Perron				Ouest avenue des Perron				Grand Total	%
	←	↑	→	Total	←	↑	→	Total	←	↑	→	Total	←	↑	→	Total		
13:00-13:15	4	140	12	156	52	174	7	233	4	4	1	9	9	5	51	65	463	1.9
13:15-13:30	0	129	19	148	25	138	5	168	1	5	7	13	10	2	48	60	389	1.6
13:30-13:45	2	157	12	171	40	162	8	210	5	8	3	16	17	6	39	62	459	1.9
13:45-14:00	3	123	7	133	42	194	2	238	5	7	4	16	13	7	48	68	455	1.9
14:00-14:15	4	160	9	173	50	207	8	265	3	6	3	12	7	3	39	49	499	2.1
14:15-14:30	4	161	19	184	44	248	11	303	1	4	6	11	16	7	50	73	571	2.4
14:30-14:45	3	164	19	186	46	228	9	283	4	9	8	21	21	7	63	91	581	2.4
14:45-15:00	2	157	16	175	81	242	8	331	7	7	16	30	15	5	48	68	604	2.5
15:00-15:15	6	135	17	158	56	316	9	381	8	10	22	40	17	3	52	72	651	2.7
15:15-15:30	3	142	10	155	50	294	6	350	8	14	17	39	22	6	38	66	610	2.6
15:30-15:45	3	156	17	176	32	320	2	354	7	17	24	48	16	5	36	57	635	2.7
15:45-16:00	2	133	12	147	40	304	4	348	6	16	29	51	17	15	34	66	612	2.6
16:00-16:15	3	127	15	145	27	216	2	245	2	11	45	58	36	19	29	84	532	2.2
16:15-16:30	3	146	24	173	27	257	2	286	3	25	36	64	34	16	39	89	612	2.6
16:30-16:45	7	150	15	172	18	208	2	228	8	20	31	59	33	17	42	92	551	2.3
16:45-17:00	2	150	25	177	15	229	0	244	3	26	28	57	37	19	39	95	573	2.4
17:00-17:15	6	118	27	151	14	206	1	221	3	19	25	47	48	19	34	101	520	2.2
17:15-17:30	1	117	17	135	23	194	3	220	4	19	35	58	36	18	27	81	494	2.1
17:30-17:45	4	127	23	154	28	229	2	259	5	26	19	50	22	8	42	72	535	2.2
17:45-18:00	2	105	10	117	26	248	2	276	2	17	24	43	19	5	46	70	506	2.1
18:00-18:15	2	96	10	108	57	251	7	315	2	14	15	31	23	10	45	78	532	2.2
18:15-18:30	3	101	11	115	54	286	5	345	0	13	10	23	22	7	51	80	563	2.4
18:30-18:45	2	113	19	134	67	272	4	343	3	14	8	25	10	8	63	81	583	2.5
18:45-19:00	2	104	10	116	80	256	5	341	1	3	4	8	9	7	39	55	520	2.2

Numéro du relevé: 0081357 Municipalité: Laval
Direction Territoriale: Laval--Mille-Îles

Avant-midi: 12-11-15 Jeudi
Après-midi: 12-11-15 Jeudi
Relevé de 7:00 à 19:00

Nord: 00335-01-140 (00+436) avenue Papineau
Sud: 00335-01-140 (00+000) avenue Papineau

Est: avenue des Perron
Ouest: avenue des Perron

	Nord avenue Papineau				Sud avenue Papineau				Est avenue des Perron				Ouest avenue des Perron				Grand Total	%
	←	↑	→	Total	←	↑	→	Total	←	↑	→	Total	←	↑	→	Total		
7:00- 7:15	0	8	0	8	1	5	0	6	0	1	1	2	1	0	1	2	18	1.5
7:15- 7:30	0	5	0	5	0	9	0	9	0	1	0	1	1	0	1	2	17	1.4
7:30- 7:45	0	6	0	6	2	5	0	7	0	1	1	2	1	2	0	3	18	1.5
7:45- 8:00	0	10	0	10	0	16	0	16	0	0	0	0	0	1	0	1	27	2.3
8:00- 8:15	0	3	1	4	1	15	0	16	0	1	0	1	0	0	2	2	23	1.9
8:15- 8:30	0	16	0	16	1	14	0	15	0	0	0	0	1	0	0	1	32	2.7
8:30- 8:45	0	8	0	8	2	16	0	18	0	0	0	0	4	0	1	5	31	2.6
8:45- 9:00	1	9	1	11	2	13	0	15	0	0	1	1	0	0	1	1	28	2.3
9:00- 9:15	1	19	2	22	6	9	0	15	0	0	0	0	0	0	0	0	37	3.1
9:15- 9:30	0	10	0	10	3	10	0	13	0	0	0	0	1	0	2	3	26	2.2
9:30- 9:45	0	9	4	13	2	11	0	13	0	0	0	0	0	1	4	5	31	2.6
9:45-10:00	1	17	0	18	0	10	0	10	0	1	1	2	0	0	1	1	31	2.6
10:00-10:15	0	11	1	12	2	7	1	10	0	0	0	0	1	0	1	2	24	2.0
10:15-10:30	0	12	1	13	3	11	0	14	0	1	1	2	0	1	5	6	35	2.9
10:30-10:45	0	18	1	19	3	14	1	18	1	0	0	1	0	1	0	1	39	3.3
10:45-11:00	0	12	0	12	3	8	0	11	0	0	0	0	0	0	1	1	24	2.0
11:00-11:15	0	7	1	8	0	8	1	9	0	0	0	0	0	0	2	2	19	1.6
11:15-11:30	0	13	0	13	1	9	0	10	0	0	0	0	0	0	1	1	24	2.0
11:30-11:45	0	9	0	9	0	12	0	12	1	1	0	2	0	0	2	2	25	2.1
11:45-12:00	0	13	0	13	4	7	1	12	2	0	0	2	0	0	0	0	27	2.3
12:00-12:15	0	11	1	12	1	10	0	11	0	0	0	0	1	0	4	5	28	2.3
12:15-12:30	0	8	0	8	1	7	0	8	0	0	0	0	0	0	1	1	17	1.4
12:30-12:45	0	13	0	13	3	8	0	11	0	0	0	0	0	0	1	1	25	2.1
12:45-13:00	1	10	2	13	1	11	0	12	0	0	0	0	1	0	1	2	27	2.3

Numéro du relevé: 0081357 Municipalité: Laval
Direction Territoriale: Laval--Mille-Îles

Avant-midi: 12-11-15 Jeudi
Après-midi: 12-11-15 Jeudi
Relevé de 7:00 à 19:00

Nord: 00335-01-140 (00+436) avenue Papineau
Sud: 00335-01-140 (00+000) avenue Papineau

Est: avenue des Perron
Ouest: avenue des Perron

	Nord avenue Papineau				Sud avenue Papineau				Est avenue des Perron				Ouest avenue des Perron				Grand Total	%
	←	↑	→	Total	←	↑	→	Total	←	↑	→	Total	←	↑	→	Total		
13:00-13:15	1	6	1	8	2	10	0	12	0	1	0	1	0	0	0	0	21	1.8
13:15-13:30	0	11	1	12	0	16	1	17	0	0	0	0	0	0	3	3	32	2.7
13:30-13:45	0	11	1	12	1	14	1	16	0	0	0	0	1	1	3	5	33	2.8
13:45-14:00	1	14	0	15	3	29	0	32	0	1	0	1	0	0	3	3	51	4.3
14:00-14:15	1	10	0	11	0	11	0	11	1	0	0	1	1	0	1	2	25	2.1
14:15-14:30	1	21	2	24	1	13	1	15	0	0	0	0	3	0	0	3	42	3.5
14:30-14:45	0	28	1	29	1	16	0	17	0	0	1	1	1	0	3	4	51	4.3
14:45-15:00	0	11	0	11	4	7	0	11	0	0	1	1	0	1	2	3	26	2.2
15:00-15:15	2	12	0	14	2	6	0	8	0	0	2	2	1	0	0	1	25	2.1
15:15-15:30	0	11	1	12	1	13	0	14	2	0	0	2	2	0	2	4	32	2.7
15:30-15:45	0	13	1	14	0	10	0	10	0	0	0	0	0	1	0	1	25	2.1
15:45-16:00	0	10	1	11	1	13	1	15	0	0	4	4	0	0	1	1	31	2.6
16:00-16:15	0	4	2	6	1	3	0	4	0	0	1	1	1	1	3	5	16	1.3
16:15-16:30	1	7	1	9	0	4	0	4	0	0	0	0	1	2	2	5	18	1.5
16:30-16:45	1	6	1	8	0	5	0	5	0	1	0	1	2	0	1	3	17	1.4
16:45-17:00	0	4	1	5	0	10	0	10	0	0	1	1	4	0	4	8	24	2.0
17:00-17:15	0	5	2	7	0	6	0	6	0	0	3	3	3	0	0	3	19	1.6
17:15-17:30	0	8	1	9	0	6	0	6	0	0	1	1	0	0	1	1	17	1.4
17:30-17:45	0	5	0	5	0	7	0	7	0	0	0	0	0	0	0	0	12	1.0
17:45-18:00	1	6	0	7	0	3	0	3	0	0	0	0	2	0	0	2	12	1.0
18:00-18:15	1	4	0	5	0	4	1	5	0	0	1	1	0	0	0	0	11	0.9
18:15-18:30	0	2	0	2	2	2	0	4	0	0	0	0	0	0	0	0	6	0.5
18:30-18:45	0	1	1	2	1	7	0	8	0	0	0	0	0	0	1	1	11	0.9
18:45-19:00	1	4	0	5	1	2	0	3	0	0	0	0	0	1	0	1	9	0.8

